

**LEADER**

**WOW & FLUTTER METER**

INSTRUCTION MANUAL

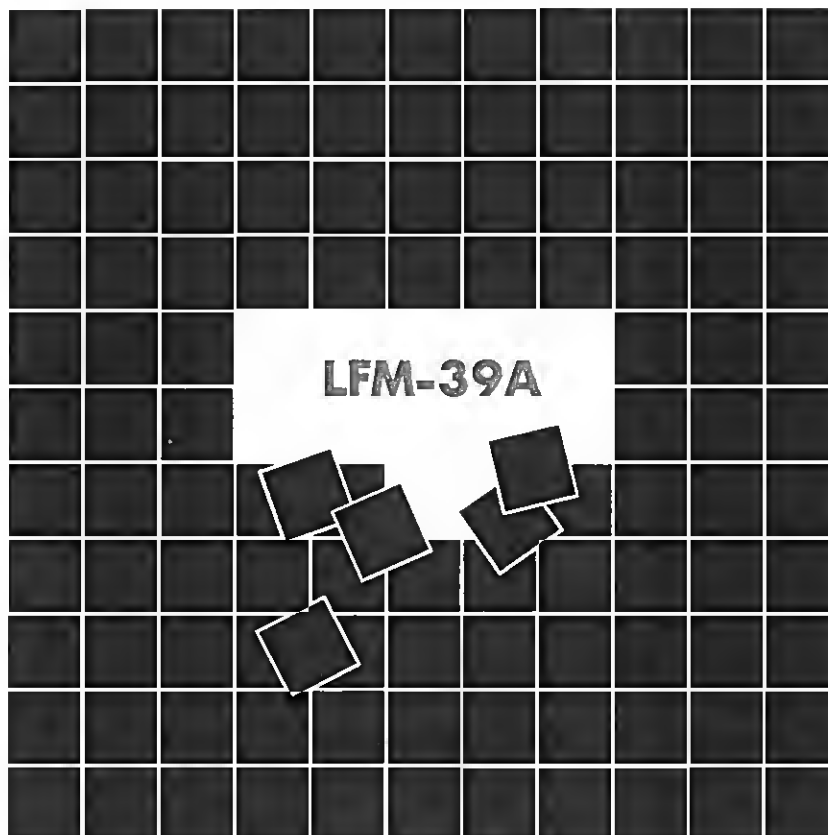

**LEADER ELECTRONICS CORP.**

## CONTENTS

	PAGE
1. DESCRIPTION .....	2
2. SPECIFICATIONS .....	2
3. CONTROLS AND TERMINALS .....	3
3.1 Front panel .....	4
3.2 Rear panel .....	5
4. OPERATION .....	6
4.1 Preparation .....	6
4.2 Tape speed (Drift) Wow & Flutter measurements .....	7
4.3 Wow & Flutter analysis .....	8
4.4 Wow & Flutter recording .....	10
5. BLOCK DIAGRAM .....	10
6. CIRCUIT DESCRIPTION .....	11
7. MAINTENANCE .....	12
7.1 Changing the fuse .....	12
7.2 How to remove the cover .....	12
7.3 Changing the voltage to correct power source voltage .....	13
8. CALIBRATION .....	14
8.1 Calibration of drift reading .....	14
8.2 Calibration of Wow & Flutter reading .....	14

## 1. Description

The LFM-39A Wow & Flutter Meter is a direct reading type instrument designed for measurement of Wow, Flutter and Drift characteristics of tape recorders, recordplayers and other playback/recording equipment. The effective values, peak-to-peak values and center frequency (3kHz or 3.15kHz) of Wow & Flutter are indicated on the meter in accordance with JIS, CCIR, DIN, and weighted specifications.

Five full scale ranges, 0.03%, 0.1%, 0.3%, 1% and 3%, are used. The use of 0.03% range makes it possible to measure accurately the Wow & Flutter characteristics of high-grade tape recorders.

The LFM-39A contains an oscillator with excellent frequency accuracy, which can be used to calibrate the drift meter and supply a recording signal.

Moreover, this Wow & Flutter meter is equipped with a TO SCOPE terminal for analyzing Wow & Flutter components and a RECORDER terminal for Wow & Flutter recording.

## 2 Specifications

### Input frequency

JIS, CCIR	3kHz $\pm 10\%$
DIN	3.15kHz $\pm 10\%$

Input voltage range . . . . . 15mV to 10Vrms

Input impedance . . . . . Over 300k $\Omega$

### Drift measurement

Range . . . . .  $\pm 5\%$

Accuracy . . . . . Within  $\pm 5\%$  of full scale

### Wow & Flutter measurement

Range . . . . . 5 ranges: 0.03%, 0.1%, 0.3%, 1% and 3%

Accuracy . . . . . Within  $\pm 5\%$  of full scale

### Wow & Flutter frequency characteristics

W & F JIS . . . . . 0.5 to 200Hz (-3dB  $\pm 1$ dB)

CCIR . . . . . 0.3 to 200Hz (-3dB  $\pm 1$ dB)

DIN . . . . . 0.3 to 300Hz (-3dB  $\pm 1$ dB)

Weighted . . . . . In accordance with JIS, CCIR and DIN specifications

Wow JIS . . . . . 0.5 to 6Hz (-3dB  $\pm 1$ dB)

CCIR, DIN . . . . . 0.3 to 6Hz (-3dB  $\pm 1$ dB)

Flutter JIS, CCIR . . . . . 6 to 200Hz (-3dB  $\pm 1$ dB)

DIN . . . . . 6 to 300Hz (-3dB  $\pm 1$ dB)

### Indicating system

JIS . . . . . Indication by Effective Value

CCIR, DIN . . . . . Indication by Peak-to-Peak Value

### Dynamic characteristics

JIS . . . . . Time required to reach 95% of the reading when proper input is applied for a maximum reading of 100% . . . . . 3.5 sec  $\pm 1$  sec



### 3.1 Front panel

- ① “% Drift” Meter (zero-center type)

This meter indicates the drift of a measured object (tape recorder and the like) and its fluctuation.

When making measurements in accordance with JIS and CCIR specifications, 0% refers to 3kHz, but refers to 3.15kHz when making measurements in accordance with DIN specifications. The reading shows the value (%) in reference to the center frequency.
- ② “Zero Adjuster”

This is a mechanical zero adjusting screw for the drift meter. Before turning on the power, set the drift meter to “0” properly by the use of an insulated screw-driver or the like.
- ③ “Input Monitor” Lamp  
The input level indicator lamp will light and indicate that the instrument is in the measuring state when a proper signal is applied to the input terminal. The lamp will light when the input frequency is 3kHz  $\pm 10\%$  in JIS and CCIR specifications and within 3.15kHz  $\pm 10\%$  in DIN specifications and when the input voltage is over 15mV.
- ④ “0 ADJ” Knob  
This is a 0% calibrating knob for the drift meter. Set the knob so that the drift meter reading will show 0% when no input is applied or the Input Monitor Lamp is not lit.
- ⑤ “INPUT” Terminals  
These are terminals for connection to the output of the tape recorder and other equipment. Use the red terminal for the “hot” lead and black terminal for common. Reverse connections may result in unproper readings.
- ⑥ “% WOW & FLUTTER” Range Switch  
This switch selects the full scale ranges on the Wow & Flutter Meter. Choose the most suitable range is indicated by the Wow & Flutter reading.  
Five full scale ranges, 0.03%, 0.1%, 0.3%, 1% and 3% are available.
- ⑦ “MODE” Selector Switch
  - A. “W & F” (Wow & Flutter)  
Use this switch when measuring overall Wow & Flutter components contained in the measured signal.
  - B. “WTD” (Weighted)  
Use this switch when making measurements of weighted characteristics in accordance with JIS, CCIR and DIN specifications. (Refer to the attached drawing.)
  - C. “WOW”  
Use this switch when measuring WOW component up to 6Hz.
  - D. “FLUTTER”  
Use this switch when measuring FLUTTER component over 6Hz.
- ⑧ “INDICATION” Selector Switch
  - A. JIS  
Use this switch when making measurements in accordance with JIS specifications.
  - B. CCIR  
Use this switch when making measurements in accordance with CCIR specifications.
  - C. DIN  
Use this switch when making measurements in accordance with DIN specifications.

- ⑨ "POWER ON" Toggle Switch  
This is a switch for applying power to the Wow & Flutter Meter. Turn the switch upward to apply power.
- ⑩ "Pilot Lamp"  
When the power switch is turned on, this pilot lamp lights and indicates power is turned on.
- ⑪ "0 Adjuster"  
This is a mechanical zero adjusting screw for the Wow & Flutter Meter. Set as in step ② above.
- ⑫ "% WOW & FLUTTER" Meter  
This is a meter for indicating the Wow & Flutter component in %.



### 3.2 Rear panel

- ⑬ Instrument Legs  
Used for vertical positioning of unit and for winding up of power cord.
- ⑭ Power Cord
- ⑮ Fuse  
Turn fuseholder cap counterclockwise to remove fuse. Replace with same type and rating.

90 to 132V	0.5A	NORMAL BLOW
180 to 250V	0.315A	NORMAL BLOW

- ⑯ "RECORDER" Terminals  
These are terminals for recording and analyzing the Wow & Flutter characteristics of equipment by connecting the pen recorder.  
Input is calibrated for 1V<sub>DC</sub> at full scale meter reading.

⑰ "TO SCOPE" Terminals

These terminals are used when monitoring the Wow & Flutter characteristics on an oscilloscope. The terminals are calibrated for 1-V<sub>rms</sub> output at full scale when making measurements in accordance with JIS and the 0.7-V<sub>rms</sub> output at full scale when making measurements in accordance with CCIR and DIN.

⑱ "OSC OUT"

Provides a 3kHz oscillator signal with 0.05% accuracy and 0.3V<sub>rms</sub> output for recorder use.

⑲ Adjustment of full scale of each "MODE" Refer to 8. Calibration for details.

#### 4. Operation

Before using the Wow & Flutter Meter, read the following instructions carefully.

##### 4.1 Preparation

1. Measurements can be made with this instrument in accordance with the following 3 standards: JIS, CCIR and DIN.

	JIS (Japanese Industrial Standards)	CCIR (International Radio Communications Committee)	DIN (West German Industrial Standards)
Center frequency	3kHz	3kHz	3.15kHz
Indication	Effective value	Peak-to-peak value	Peak-to-peak value
Frequency characteristic	0.5Hz – 200Hz	0.3Hz – 200Hz	0.3Hz – 300Hz
Weighted characteristic	JIS C-5551	(Standards common to JIS)	Standards common to JIS)

As shown in the above table, there are points of difference in each standard, and, therefore the measured results greatly vary with the presence of a weighted circuit as well as with the standards on which measurements are to be made.

2. Set zero

When the "Monitor" lamp on the panel is not lit, the internal 3 kHz output is automatically connected and the instrument is ready to be set to zero. Adjust the 0 ADJ knob so that the drift meter indicates 0%.

Unless this zero adjustment is properly performed, no correct measurement can be made.

## 4.2 Tape speed (Drift) and Wow & Flutter measurements

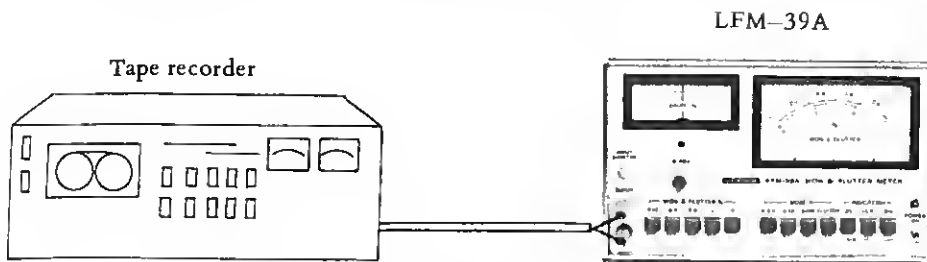

Fig. 4-1

Connect the tape recorder to the LFM-39A as shown in Fig. 4-1.

Before starting measurements, set each switch on the LFM-39A as follows.

WOW & FLUTTER Range . . . . . 3%  
MODE . . . . . WTD or W & F  
INDICATION . . . . . Values to be measured in accordance with JIS, CCIR  
or DIN

Apply the signal to be measured to the input terminal. At this time, if the input voltage is over 15mV and the frequency is 3kHz  $\pm 10\%$  in JIS and CCIR specifications and within 3.15kHz  $\pm 10\%$  in DIN specifications, the "MONITOR" lamp on the input terminal will light and indicates measurements may be made.

Then, observe indication on the flutter meter and select a proper range with the "WOW & FLUTTER" range switch so that the reading is over 1/3 of meter full scale.

The measured value should be read as " " % rms when taking measurements in accordance with JIS specifications and " " % p-p in accordance with CCIR and DIN specifications.

These measurements may be broadly classified into the following two methods.

### A. Standard tape playback method

A tape in which an accurate signal of 3kHz is recorded is commercially available as a standard tape for measuring Wow & Flutter. (TEAC MTT-111 or equivalent)

### B. Recording/playback method

This is a method of measurement by playing back the tape after recording the OSC OUT (3kHz) signal of the LFM-39A on the tape recorder to be measured.

### (Notes)

Generally, method B is less accurate than method A. In addition the built-in oscillator of the LFM-39A is 3kHz in the standard model and DIN measurements require 3.15kHz.

(The 3.15kHz oscillator is available upon request as a special order.)

### (Reference)

Test method for tape recorders (extracted from JIS C5551)

#### Deviation in tape speed

Play back the tape speed test tape with a test tape recorder and measure the frequency of its playback output signal. Then, calculate the deviation by the following formula.



$$\text{Deviation (\%)} = \frac{f - f_0}{f_0} \times 100$$

Where,

$f_0$  : Frequency of signal recorded in the test tape (Hz)

$f$  : Frequency of signal when the test tape has been played back (Hz)

Use the maximum reel conforming to a test tape recorder and take measurements at three places; beginning, middle and end of tape winding. Of the average of three measurements, deviation in reference to the rated value at maximum speed and minimum speed shall be expressed in percentage (%).

Measurement time at any one place shall be not less than 10 seconds.

#### Wow & Flutter

Play back the Wow & Flutter test tape with the tape recorder to be measured. Measure its output with the Wow & Flutter meter calibrated in terms of effective values including a weighted circuit. Indication will be in percentage (%).

Use the maximum reel conforming to the tape recorder to be measured and take measurements at three places: beginning, middle and end of tape winding. Of the values obtained at each place, the maximum value will be indicated.

### 4.3 Wow & Flutter analysis

#### 1. Separate measurement of Wow and Flutter

This instrument permits separate measurements of wow component and flutter component. The wow and flutter are rotational distortions produced in the mechanical portion of equipment. Their generating frequencies can, therefore, be determined by the shapes of each part.

For example, in case of a tape recorder, the belt, etc. can be measured as the wow component while the capstan and pinch roller can be measured as the flutter component. If measurement is made by separating the wow and flutter after measuring the whole band at W & F, therefore, the cause of trouble in the tape recorder can be detected.

#### 2. Using the oscilloscope

As shown in Fig. 4-2, connect the oscilloscope to the TO SCOPE Terminal.

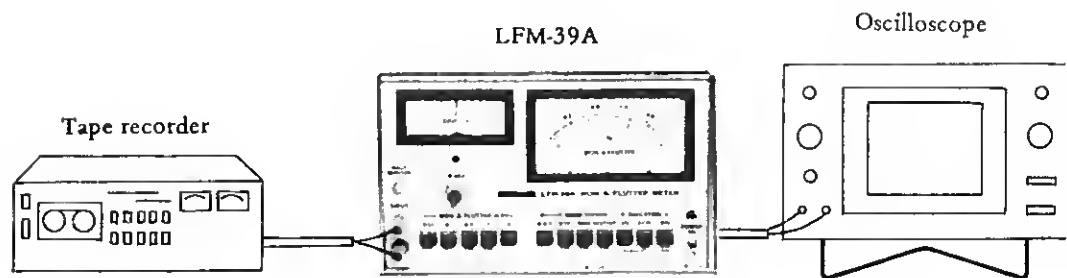

Fig. 4-2

The output waveform of this TO SCOPE terminal is capable of monitoring all Wow & Flutter components irrespective of Mode switching operation. From the time axis of the oscilloscope, you may read the Wow & Flutter components.

The output voltage is 1Vrms at full scale in accordance with JIS and 0.7Vrms at full scale in accordance with CCIR and DIN.

Applicable Standards	Output Voltage
JIS	1 Vrms
CCIR, DIN	0.7 Vrms

The output impedance is  $2\text{ k}\Omega \pm 20\%$ .

#### 4.4 Wow & Flutter recording

When recording and analyzing the measured Wow & Flutter as data, connect the pen recorder to the recorder terminal as shown in Fig. 4-3.

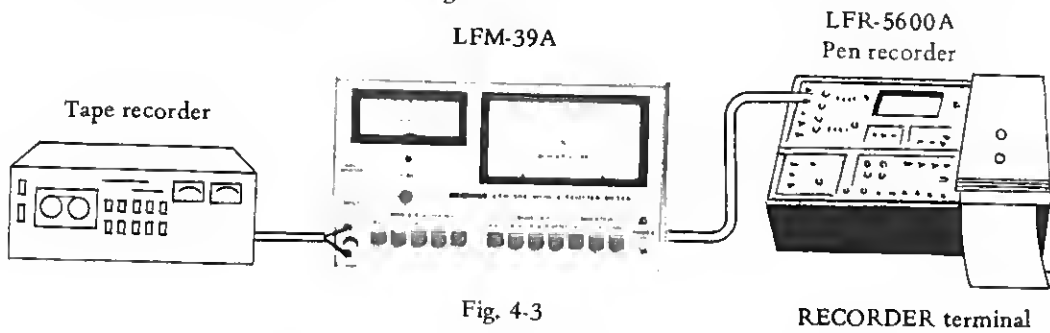

Fig. 4-3

The tape recorder output is the input voltage of the Wow & Flutter meter and can be read directly on the LFM-39A. The recorder output is 1 Vrms full scale and its output impedance is  $2\text{ k}\Omega \pm 20\%$ .

## 5. Block Diagram

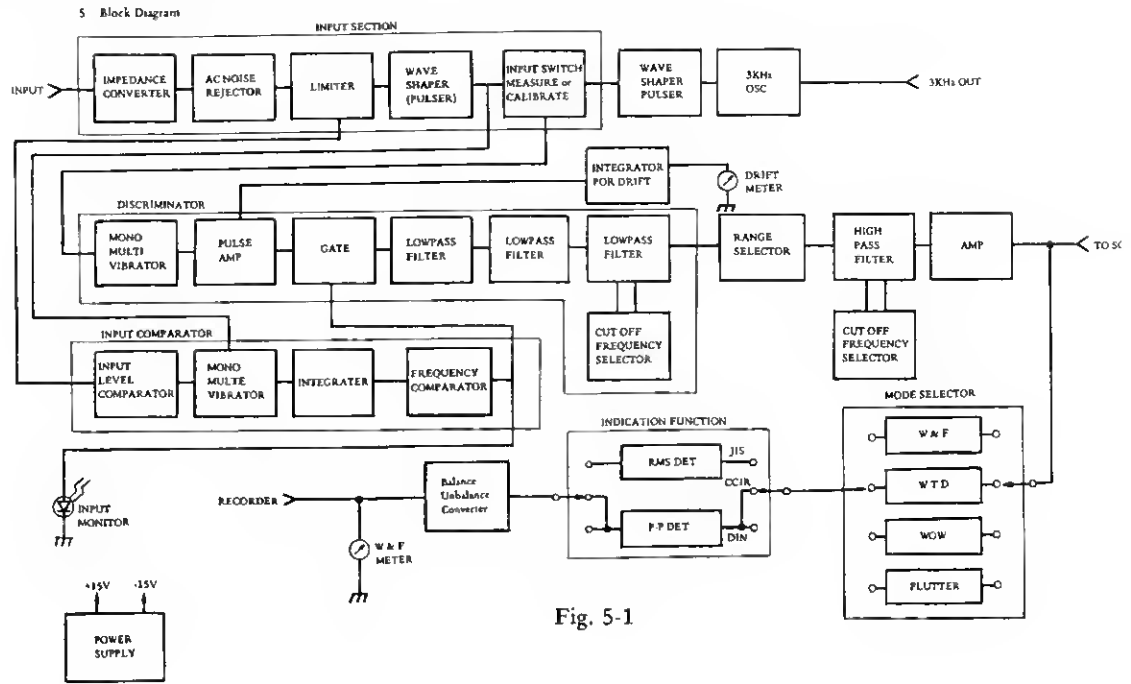

Fig. 5-1

## 6. Circuit Description

### 6.1 Input section

The input section consists of an impedance converter, an AC noise rejector, a limiter, a wave shaper and an input switch.

The input signal is converted into proper input impedance through the impedance converter and enters the input circuit. The AC hum component is removed by the AC noise rejector and other noise components are removed by the limiter. Then, the input signal is shaped into a pulse. The input switch turns on the input signal and the 3kHz internal oscillator reference signal.

### 6.2 3-kHz Reference signal oscillator circuit

The 3 kHz reference signal may be used as a test signal for recording and is available at the output terminals.

### 6.3 Discriminator

The discriminator consists of a mono-multivibrator, a pulse amplifier, a gate and a low-pass filter. The input signal which has been shaped in the input section enters the mono-multivibrator, is corrected to a constant pulse width, passes through the pulse amplifier and gate, and is taken out as a Wow & Flutter component of 200 Hz (or less than 300 Hz) through the low-pass filter. The low-pass filter has its cut-off frequency changed by the "INDICATION" switch as shown below.

JIS, CCIR	200Hz (-3dB ± 1dB)
DIN	300Hz (-3dB ± 1dB)

### 6.4 Range selector, high-pass filter, amplifier

The W & F signal produced in the discriminator enters the high-pass filter through the range selected. The high-pass filter has its cut-off frequency changed by the "INDICATION" switches as shown below.

JIS	0.5Hz (-3dB ± 1dB)
CCIR, DIN	0.3Hz (-3dB ± 1dB)

### 6.5 Mode selector

The following measurements can be performed by means of this mode selector switch.

W & F	: Measurement of wow and flutter
WTD	: Weighted measurement
WOW	: Measurement of wow component under 6Hz
FLUTTER	: Measurement of flutter component over 6Hz

The characteristic curves of WTD are shown at the end of this instruction manual.

## 6.6 Indication function

The W & F component with acoustic compensation is detected (RMS or P-P) to obtain the indication corresponding to JIS, CCIR or DIN specifications.

JIS	RMS detection
CCIR, DIN	P-P detection

## 6.7 Drift meter

When the mono-multivibrator output of the discriminator is integrated with the integrator, it drives the meter as a drift component.

## 6.8 Input comparator

The control signal from the input comparator applies the input signal to the discriminator and opens or closes the gate.

The input level comparator judges whether there is more than 15 mV<sub>rms</sub> of input signal or not. If there is more than 15 mV<sub>rms</sub>, the input signal is supplied to the mono-multivibrator and converted into a pulse. This pulse is integrated with the integrator, and the frequency comparator functions to judge whether the frequency is within 3kHz  $\pm 10\%$  (3.15kHz  $\pm 10\%$  in DIN indication) or not. If it is within  $\pm 10\%$ , the control signal closes the gate to pass the input signal through and simultaneously lights up the input monitor.

## 7. Maintenance

### 7.1 Changing the fuse

The fuse can be removed by turning the fuse holder at the rear in the direction of the arrow.

90 to 132V	0.5A NORMAL BLOW
180 to 250V	0.315A NORMAL BLOW

If there is an open fuse, check the cause and repair fault. Replace the fuse with a new one and turn on the power.

### 7.2 How to remove the cover

The cover can be removed by taking off 6 Phillips head screws (3mm) as shown in Fig. 7-

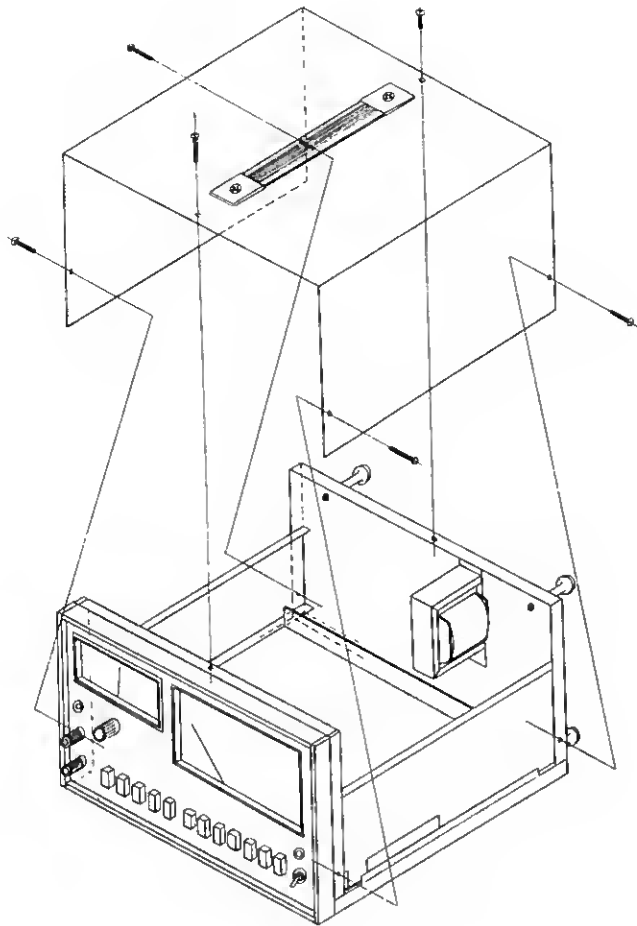

Fig. 7-1

### 7.3 Changing the voltage to the correct power source voltage

The power transformer is on the rear side when the case is opened. The terminals numbered 1, 2, 3 and 1, 2, 3 are primary ones. When changing the voltage of the applied power source, change wiring as shown in Fig. 7-2.

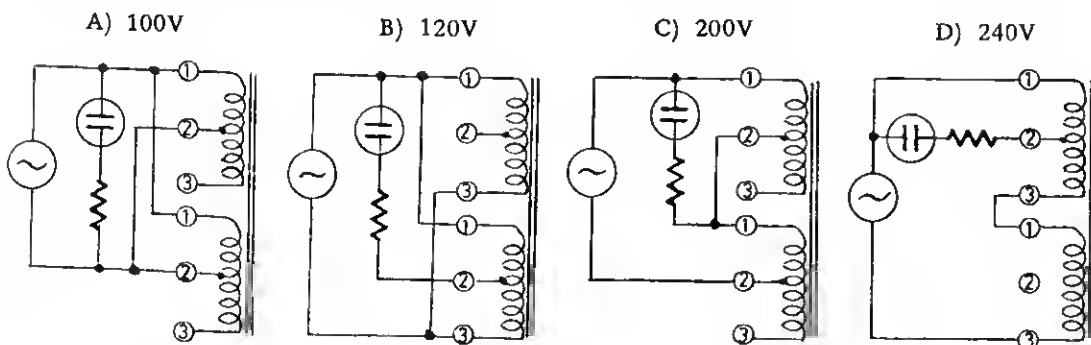

Fig. 7-2

## 8. Calibration

This instrument has been adjusted, checked and calibrated before delivery. If calibration is required because of periodic inspection or replacement of components note the following points.

- 1) This instrument and calibrating devices to be used should be turned on for at least 30 minutes.
- 2) Measurement and calibrating instruments of high accuracy should be used.
- 3) Carefully read and follow all instruction manual information on calibrating and measuring instruments.

### 8.1 Calibration of drift reading

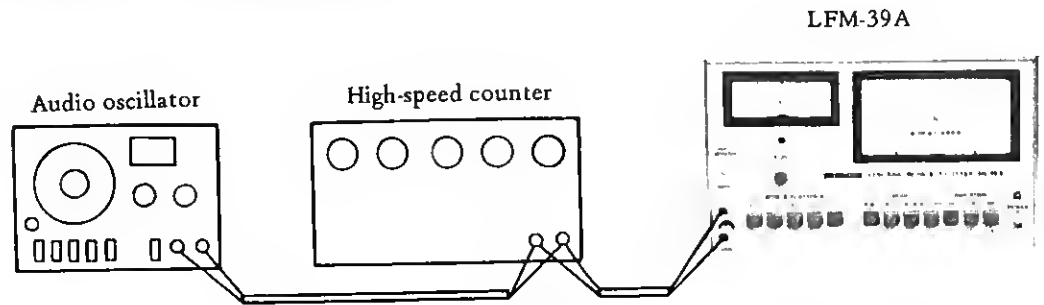

Fig. 8-1

First, make zero adjustment at a state in which no input is applied to the LFM-39A, set the oscillator and counter (high-speed counter is desirable) as shown in Fig. 8-1, then conduct calibration as follows:

- 1) Set the LFM-39A to JIS or CCIR.
- 2) Adjust VR4 to indicate  $-5\%$  at 2850Hz and  $+5\%$  at 3150Hz.
- 3) Set the LFM-39A to DIN.
- 4) Adjust VR3 so that the drift meter will indicate  $0\%$  when 3150Hz is applied to the input.

### 8.2 Calibration of Wow & Flutter reading

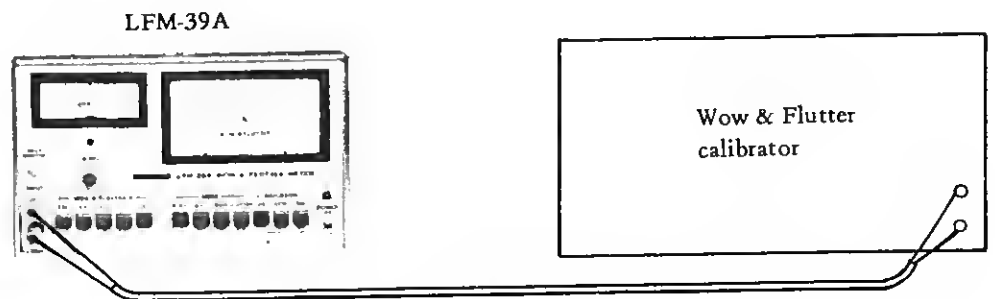
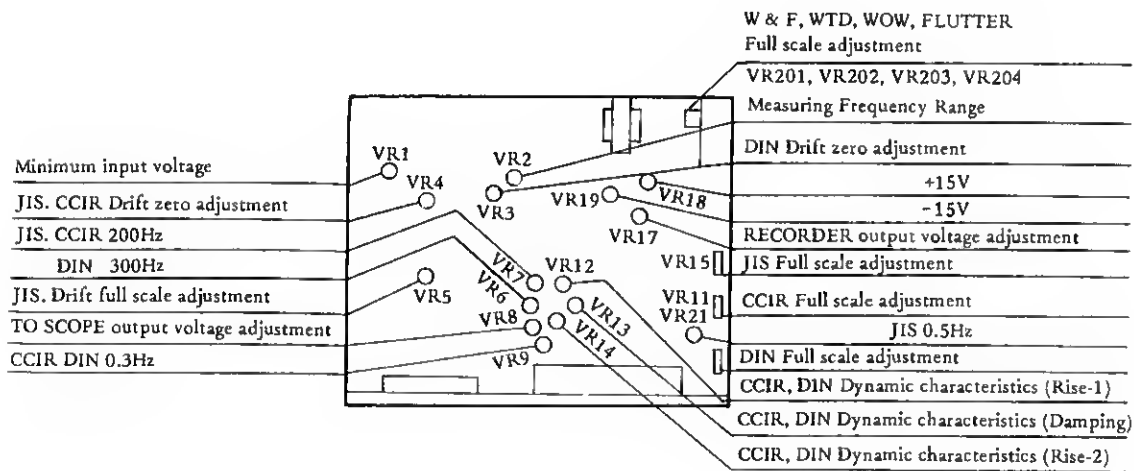

Fig. 8-2

Connect the Wow & Flutter calibrator to the LFM-39A as shown in Fig. 8-2 and conduct calibration as follows:

- 1) Set the LFM-39A to 1%, JIS and W & F.
- 2) Apply the input signal of JIS, 1%, 4Hz by means of the calibrator.
- 3) Adjust VR15 (JIS) (right-hand adjusting hole) to full scale.
- 4) Next, set the LFM-39A to 1%, JIS and WTD.
- 5) Adjust VR202 (WTD) (adjusting hole in the rear) to full scale.
- 6) Next, set the LFM-39A to 1%, JIS and WOW.
- 7) Apply the input signal of JIS, 1%, 1.5Hz by means of the calibrator.
- 8) Adjust VR203 (WOW) (adjusting hole in the rear) to full scale.
- 9) Next, set the LFM-39A to 1%, JIS and FLUTTER.
- 10) Apply the input signal of JIS, 1%, 40Hz by means of the calibrator.
- 11) Adjust VR204 (FLUTTER) (adjusting hole in the rear) to full scale.
- 12) Next, set the LFM-39A to 1%, CCIR and W & F.
- 13) Apply the input signal of CCIR, 1%, 4Hz by means of the calibrator.
- 14) Adjust VR11 (CCIR) (right-hand adjusting hole) to full scale.
- 15) Next, set the LFM-39A to 1%, DIN and W & F.
- 16) Apply the input signal of DIN, 1%, 4Hz by means of the calibrator.
- 17) Adjust VR20 (DIN) (right-hand adjusting hole) to full scale.

Calibration of the Wow & Flutter meter is now completed. However, if a Wow & Flutter calibrator is not available or when it is necessary to adjust or calibrate dynamic characteristics other than those mentioned above, contact the Service Section, Leader Electronics Corp.





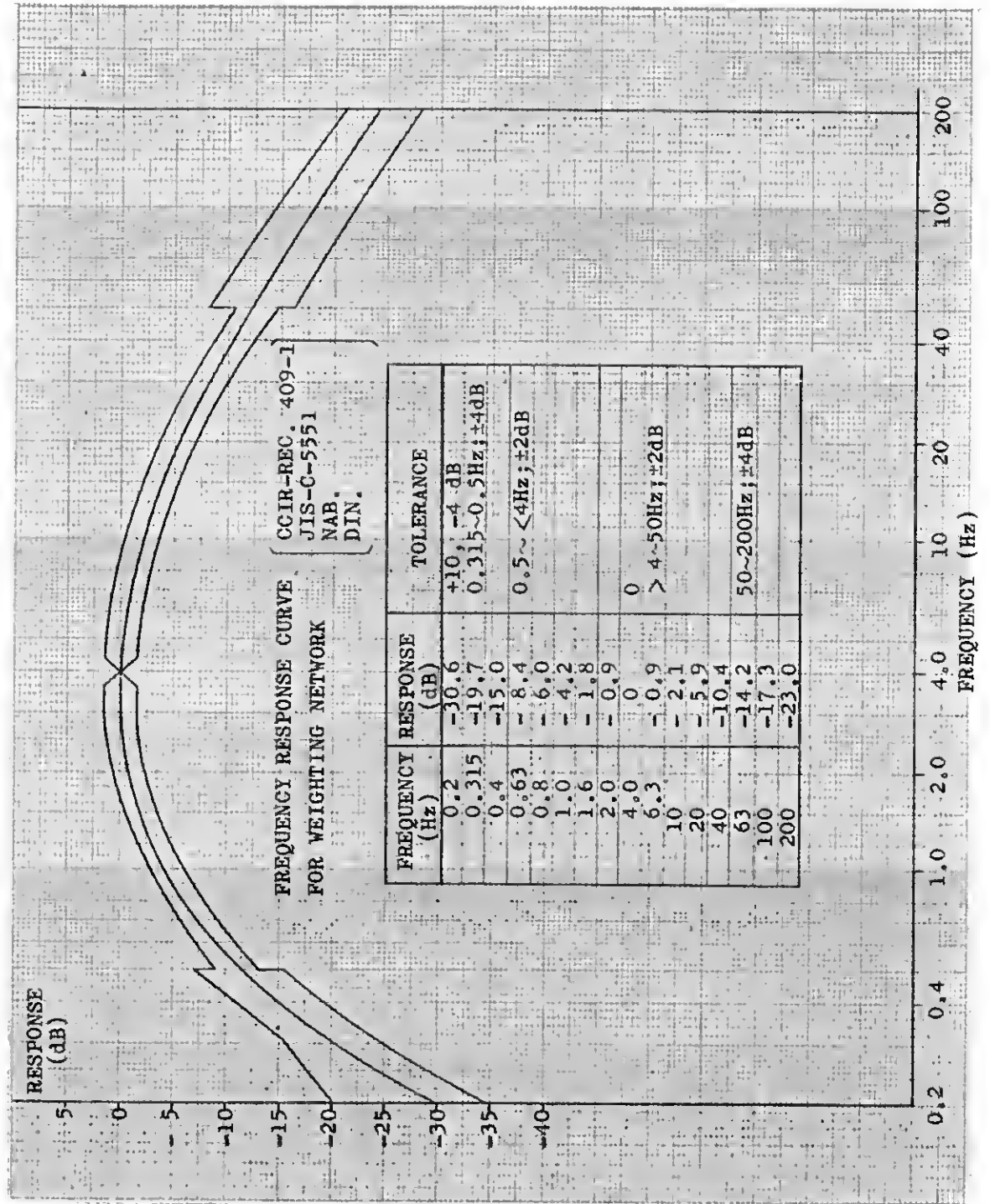

TO T-1295A

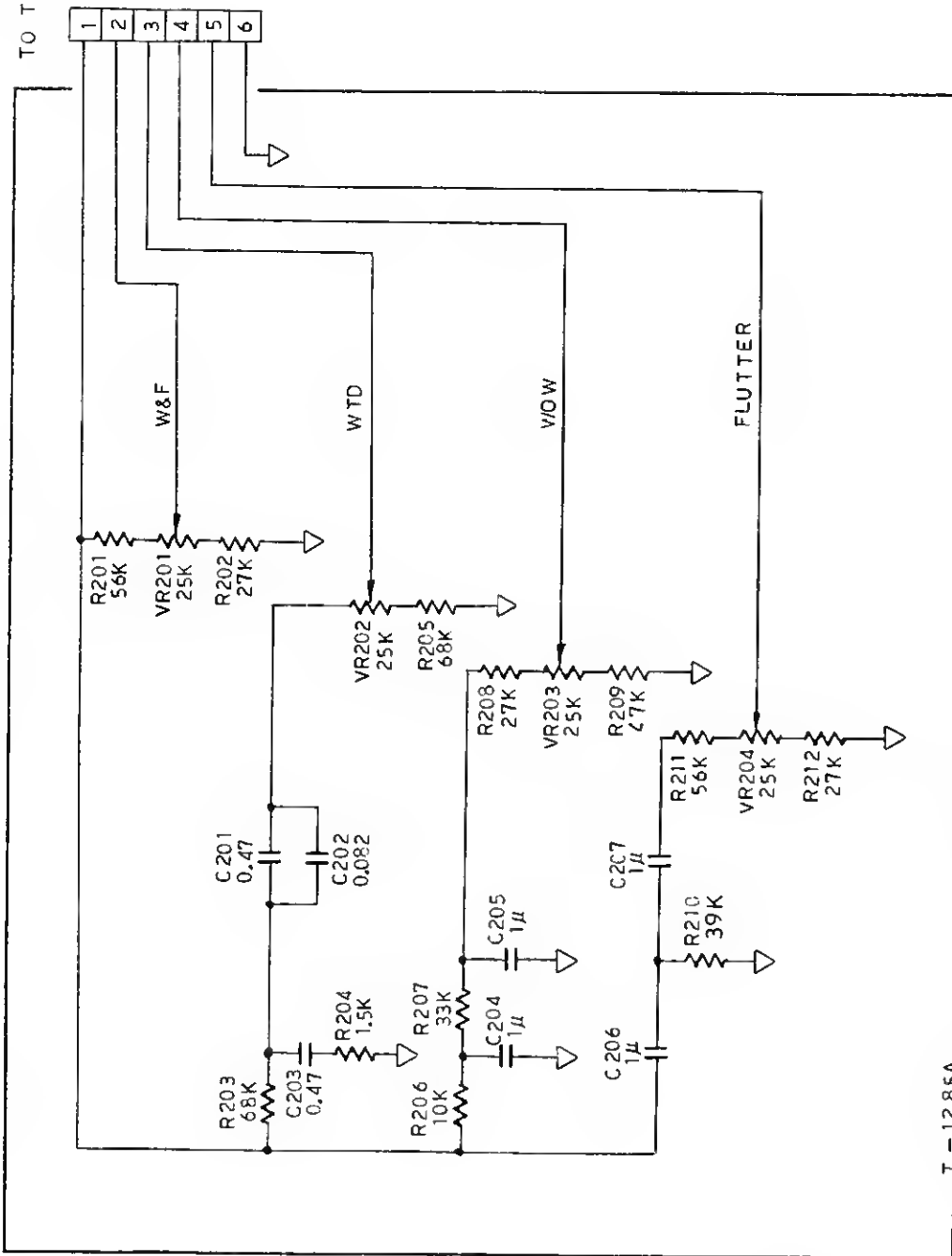

T-1285A

SCHEMATIC	Model LFM-39A	0 - 1068
FILTER	WOW FLUTTER METER	LEADER ELECTRONICS CORP.

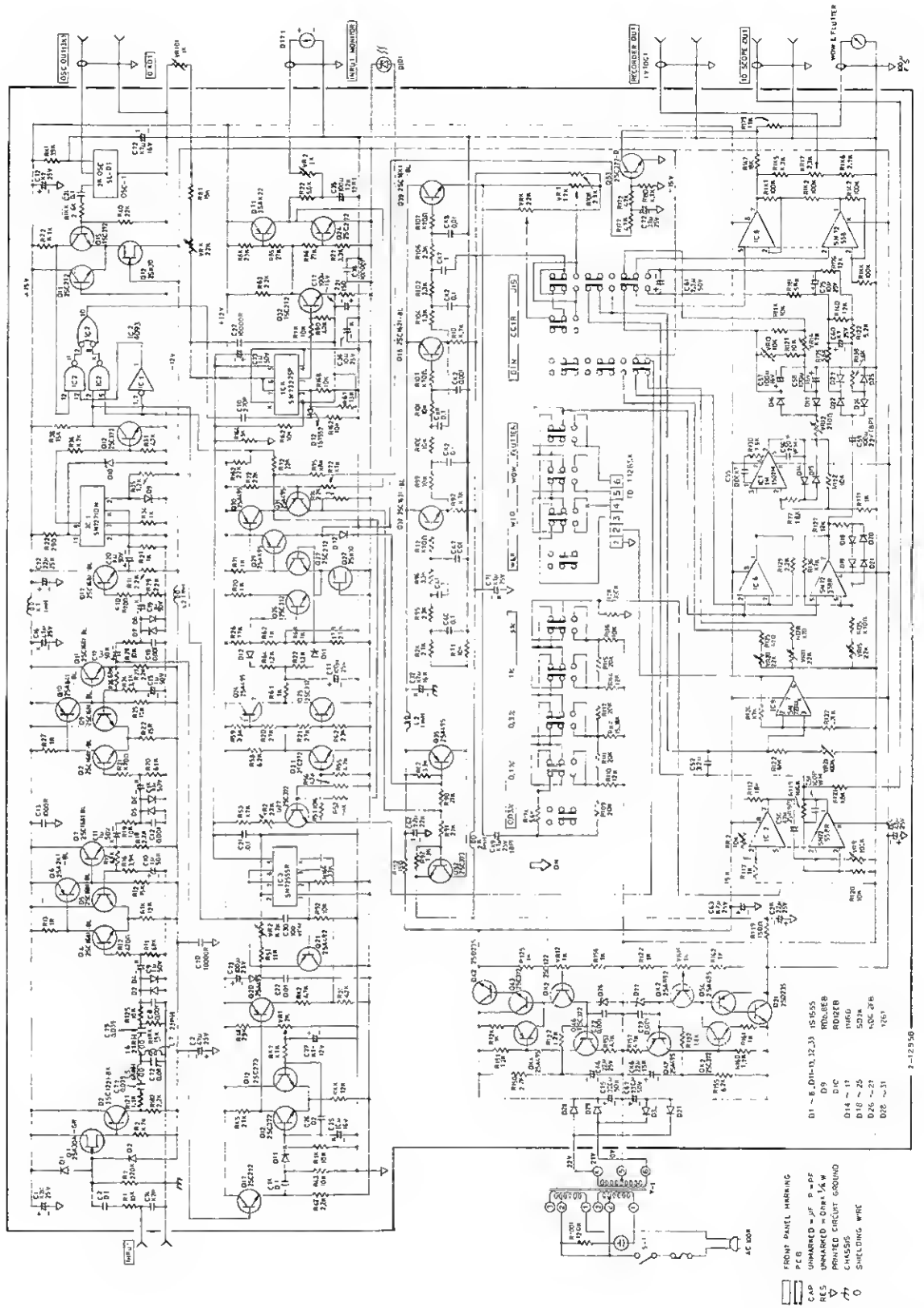

FRONT PANEL MARKING  
 PC UNMARKED - 1/2" P-OF  
 RES UNMARKED - 0.1% 1/4 W  
 CAP PRINTED CIRCUIT BOARD  
 CHASSIS  
 SHIELDING WIRE

- D1 - 6.0D1-12.33 6S655
- D2 - 6.0D1-12.33 6S655
- D3 - 6.0D1-12.33 6S655
- D4 - 6.0D1-12.33 6S655
- D5 - 6.0D1-12.33 6S655
- D6 - 6.0D1-12.33 6S655
- D7 - 6.0D1-12.33 6S655
- D8 - 6.0D1-12.33 6S655
- D9 - 6.0D1-12.33 6S655
- D10 - 6.0D1-12.33 6S655
- D11 - 6.0D1-12.33 6S655
- D12 - 6.0D1-12.33 6S655
- D13 - 6.0D1-12.33 6S655
- D14 - 6.0D1-12.33 6S655
- D15 - 6.0D1-12.33 6S655
- D16 - 6.0D1-12.33 6S655
- D17 - 6.0D1-12.33 6S655
- D18 - 6.0D1-12.33 6S655
- D19 - 6.0D1-12.33 6S655
- D20 - 6.0D1-12.33 6S655
- D21 - 6.0D1-12.33 6S655
- D22 - 6.0D1-12.33 6S655
- D23 - 6.0D1-12.33 6S655
- D24 - 6.0D1-12.33 6S655
- D25 - 6.0D1-12.33 6S655
- D26 - 6.0D1-12.33 6S655
- D27 - 6.0D1-12.33 6S655
- D28 - 6.0D1-12.33 6S655
- D29 - 6.0D1-12.33 6S655
- D30 - 6.0D1-12.33 6S655
- D31 - 6.0D1-12.33 6S655
- D32 - 6.0D1-12.33 6S655
- D33 - 6.0D1-12.33 6S655
- D34 - 6.0D1-12.33 6S655
- D35 - 6.0D1-12.33 6S655
- D36 - 6.0D1-12.33 6S655
- D37 - 6.0D1-12.33 6S655
- D38 - 6.0D1-12.33 6S655
- D39 - 6.0D1-12.33 6S655
- D40 - 6.0D1-12.33 6S655
- D41 - 6.0D1-12.33 6S655
- D42 - 6.0D1-12.33 6S655
- D43 - 6.0D1-12.33 6S655
- D44 - 6.0D1-12.33 6S655
- D45 - 6.0D1-12.33 6S655
- D46 - 6.0D1-12.33 6S655
- D47 - 6.0D1-12.33 6S655
- D48 - 6.0D1-12.33 6S655
- D49 - 6.0D1-12.33 6S655
- D50 - 6.0D1-12.33 6S655
- D51 - 6.0D1-12.33 6S655
- D52 - 6.0D1-12.33 6S655
- D53 - 6.0D1-12.33 6S655
- D54 - 6.0D1-12.33 6S655
- D55 - 6.0D1-12.33 6S655
- D56 - 6.0D1-12.33 6S655
- D57 - 6.0D1-12.33 6S655
- D58 - 6.0D1-12.33 6S655
- D59 - 6.0D1-12.33 6S655
- D60 - 6.0D1-12.33 6S655
- D61 - 6.0D1-12.33 6S655
- D62 - 6.0D1-12.33 6S655
- D63 - 6.0D1-12.33 6S655
- D64 - 6.0D1-12.33 6S655
- D65 - 6.0D1-12.33 6S655
- D66 - 6.0D1-12.33 6S655
- D67 - 6.0D1-12.33 6S655
- D68 - 6.0D1-12.33 6S655
- D69 - 6.0D1-12.33 6S655
- D70 - 6.0D1-12.33 6S655
- D71 - 6.0D1-12.33 6S655
- D72 - 6.0D1-12.33 6S655
- D73 - 6.0D1-12.33 6S655
- D74 - 6.0D1-12.33 6S655
- D75 - 6.0D1-12.33 6S655
- D76 - 6.0D1-12.33 6S655
- D77 - 6.0D1-12.33 6S655
- D78 - 6.0D1-12.33 6S655
- D79 - 6.0D1-12.33 6S655
- D80 - 6.0D1-12.33 6S655
- D81 - 6.0D1-12.33 6S655
- D82 - 6.0D1-12.33 6S655
- D83 - 6.0D1-12.33 6S655
- D84 - 6.0D1-12.33 6S655
- D85 - 6.0D1-12.33 6S655
- D86 - 6.0D1-12.33 6S655
- D87 - 6.0D1-12.33 6S655
- D88 - 6.0D1-12.33 6S655
- D89 - 6.0D1-12.33 6S655
- D90 - 6.0D1-12.33 6S655
- D91 - 6.0D1-12.33 6S655
- D92 - 6.0D1-12.33 6S655
- D93 - 6.0D1-12.33 6S655
- D94 - 6.0D1-12.33 6S655
- D95 - 6.0D1-12.33 6S655
- D96 - 6.0D1-12.33 6S655
- D97 - 6.0D1-12.33 6S655
- D98 - 6.0D1-12.33 6S655
- D99 - 6.0D1-12.33 6S655
- D100 - 6.0D1-12.33 6S655

**MEMO**